

INTERNATIONAL STANDARD

**Environmental testing –
Part 2-52: Tests – Test Kb: Salt mist, cyclic (sodium chloride solution)**



THIS PUBLICATION IS COPYRIGHT PROTECTED
Copyright © 2017 IEC, Geneva, Switzerland

All rights reserved. Unless otherwise specified, no part of this publication may be reproduced or utilized in any form or by any means, electronic or mechanical, including photocopying and microfilm, without permission in writing from either IEC or IEC's member National Committee in the country of the requester. If you have any questions about IEC copyright or have an enquiry about obtaining additional rights to this publication, please contact the address below or your local IEC member National Committee for further information.

IEC Central Office
3, rue de Varembe
CH-1211 Geneva 20
Switzerland

Tel.: +41 22 919 02 11
Fax: +41 22 919 03 00
info@iec.ch
www.iec.ch

About the IEC

The International Electrotechnical Commission (IEC) is the leading global organization that prepares and publishes International Standards for all electrical, electronic and related technologies.

About IEC publications

The technical content of IEC publications is kept under constant review by the IEC. Please make sure that you have the latest edition, a corrigenda or an amendment might have been published.

IEC Catalogue - webstore.iec.ch/catalogue

The stand-alone application for consulting the entire bibliographical information on IEC International Standards, Technical Specifications, Technical Reports and other documents. Available for PC, Mac OS, Android Tablets and iPad.

IEC publications search - www.iec.ch/searchpub

The advanced search enables to find IEC publications by a variety of criteria (reference number, text, technical committee,...). It also gives information on projects, replaced and withdrawn publications.

IEC Just Published - webstore.iec.ch/justpublished

Stay up to date on all new IEC publications. Just Published details all new publications released. Available online and also once a month by email.

Electropedia - www.electropedia.org

The world's leading online dictionary of electronic and electrical terms containing 20 000 terms and definitions in English and French, with equivalent terms in 16 additional languages. Also known as the International Electrotechnical Vocabulary (IEV) online.

IEC Glossary - std.iec.ch/glossary

65 000 electrotechnical terminology entries in English and French extracted from the Terms and Definitions clause of IEC publications issued since 2002. Some entries have been collected from earlier publications of IEC TC 37, 77, 86 and CISPR.

IEC Customer Service Centre - webstore.iec.ch/csc

If you wish to give us your feedback on this publication or need further assistance, please contact the Customer Service Centre: csc@iec.ch.

Copyright International Electrotechnical Commission



IEC 60068-2-52

Edition 3.0 2017-11

INTERNATIONAL STANDARD

**Environmental testing –
Part 2-52: Tests – Test Kb: Salt mist, cyclic (sodium chloride solution)**

INTERNATIONAL
ELECTROTECHNICAL
COMMISSION

ICS 19.040

ISBN 978-2-8322-5004-4

Warning! Make sure that you obtained this publication from an authorized distributor.

CONTENTS

FOREWORD	4
INTRODUCTION	6
1 Scope	7
2 Normative references	7
3 Terms and definitions	7
4 General description of the test	7
4.1 Description of each test condition	7
4.1.1 General	7
4.1.2 Salt mist	8
4.1.3 Dry condition	8
4.1.4 Humid condition	8
4.1.5 Standard atmosphere	8
5 Test apparatus	8
5.1 General	8
5.2 Salt mist chamber	8
5.3 Humidity chamber	8
5.4 Standard atmosphere chamber	9
5.5 Dry chamber	9
6 Salt solution	9
6.1 Preparation of the sodium chloride solution	9
6.2 pH adjustment	9
6.2.1 Neutral salt solution	9
6.2.2 Acidified salt solution	9
6.3 Filtration	9
7 Initial measurements	9
8 Preconditioning	9
9 Testing	9
9.1 Test chamber	9
9.2 Arrangement of the test specimen(s)	10
9.3 Conditions during salt mist	10
9.4 Test methods	10
9.4.1 General	10
9.4.2 Test method 1	10
9.4.3 Test method 2	10
9.4.4 Test method 3	10
9.4.5 Test method 4	11
9.4.6 Test method 5	11
9.4.7 Test method 6	11
9.4.8 Test method 7	11
9.4.9 Test method 8	11
9.5 Test cycles for test methods 1 to 8	11
9.6 Removal of the test specimen(s)	12
10 Recovery (at the end of testing)	12
11 Final measurements	13
12 Information to be given in the relevant specification	13

13 Information to be given in the test report..... 13

Annex A (informative) Typical apparatus for cyclic salt mist, humid condition, dry condition and standard atmosphere corrosion tests..... 14

Annex B (informative) Description of each test method 15

 B.1 Test methods 1 and 2 15

 B.2 Test methods 3 to 6 15

 B.3 Test methods 7 and 8 15

Bibliography..... 16

Figure A.1 – Example of test apparatus 14

Table 1 – Test cycles for test methods 1 to 8 12

www.iec.ch

INTERNATIONAL ELECTROTECHNICAL COMMISSION

ENVIRONMENTAL TESTING –

Part 2-52: Tests – Test Kb: Salt mist, cyclic (sodium chloride solution)

FOREWORD

- 1) The International Electrotechnical Commission (IEC) is a worldwide organization for standardization comprising all national electrotechnical committees (IEC National Committees). The object of IEC is to promote international co-operation on all questions concerning standardization in the electrical and electronic fields. To this end and in addition to other activities, IEC publishes International Standards, Technical Specifications, Technical Reports, Publicly Available Specifications (PAS) and Guides (hereafter referred to as “IEC Publication(s)”). Their preparation is entrusted to technical committees; any IEC National Committee interested in the subject dealt with may participate in this preparatory work. International, governmental and non-governmental organizations liaising with the IEC also participate in this preparation. IEC collaborates closely with the International Organization for Standardization (ISO) in accordance with conditions determined by agreement between the two organizations.
- 2) The formal decisions or agreements of IEC on technical matters express, as nearly as possible, an international consensus of opinion on the relevant subjects since each technical committee has representation from all interested IEC National Committees.
- 3) IEC Publications have the form of recommendations for international use and are accepted by IEC National Committees in that sense. While all reasonable efforts are made to ensure that the technical content of IEC Publications is accurate, IEC cannot be held responsible for the way in which they are used or for any misinterpretation by any end user.
- 4) In order to promote international uniformity, IEC National Committees undertake to apply IEC Publications transparently to the maximum extent possible in their national and regional publications. Any divergence between any IEC Publication and the corresponding national or regional publication shall be clearly indicated in the latter.
- 5) IEC itself does not provide any attestation of conformity. Independent certification bodies provide conformity assessment services and, in some areas, access to IEC marks of conformity. IEC is not responsible for any services carried out by independent certification bodies.
- 6) All users should ensure that they have the latest edition of this publication.
- 7) No liability shall attach to IEC or its directors, employees, servants or agents including individual experts and members of its technical committees and IEC National Committees for any personal injury, property damage or other damage of any nature whatsoever, whether direct or indirect, or for costs (including legal fees) and expenses arising out of the publication, use of, or reliance upon, this IEC Publication or any other IEC Publications.
- 8) Attention is drawn to the Normative references cited in this publication. Use of the referenced publications is indispensable for the correct application of this publication.
- 9) Attention is drawn to the possibility that some of the elements of this IEC Publication may be the subject of patent rights. IEC shall not be held responsible for identifying any or all such patent rights.

International Standard IEC 60068-2-52 has been prepared by IEC technical committee 104: Environmental conditions, classification and methods of test.

This third edition cancels and replaces the second edition published in 1996. This edition constitutes a technical revision.

This edition includes the following significant technical changes with respect to the previous edition:

- a) the entire content has been harmonized with ISO 9227 as far as possible;
- b) an introduction has been added;
- c) the scope has been simplified;
- d) normative references have been updated;
- e) the general description of the test has been changed;

- f) a dry chamber has been added to the test apparatus;
- g) severities have been changed to test methods;
- h) test methods 7 and 8 have been added;
- i) information on the test report has been added;
- j) Figure 1 has been changed to Table 1;
- k) a typical test apparatus example has been added in a new Annex A;
- l) a description of each test method has been added in a new Annex B;
- m) bibliographical references have been added.

The text of this International Standard is based on the following documents:

FDIS	Report on voting
104/751/FDIS	104/761/RVD

Full information on the voting for the approval of this International Standard can be found in the report on voting indicated in the above table.

This document has been drafted in accordance with the ISO/IEC Directives, Part 2.

A list of all parts in the IEC 60068 series, published under the general title *Environmental testing*, can be found on the IEC website.

The committee has decided that the contents of this document will remain unchanged until the stability date indicated on the IEC website under "<http://webstore.iec.ch>" in the data related to the specific document. At this date, the document will be

- reconfirmed,
- withdrawn,
- replaced by a revised edition, or
- amended.

A bilingual version of this publication may be issued at a later date.

INTRODUCTION

The mechanism of corrosion on metallic materials in a chloride-containing atmosphere is electrochemical, whereas the degradation effects experienced on non-metallic materials are caused by complex chemical reactions of the salts with the materials involved. The rate at which corrosive action takes place is dependent, to a large extent, on the supply of oxygenated salt solution to the surface of the test specimen(s), the temperature of the test specimen(s) and the temperature and humidity of the environment.

Apart from the corrosive effects, this cyclic salt mist test may be used to indicate deterioration of some non-metallic materials by assimilation of salts. In the various test methods described in this document, the period of spraying with the relevant salt solution is sufficient to wet the test specimen(s) thoroughly. Because this wetting is repeated after intervals of storage under humid conditions supplemented by storage under a standard atmosphere, it goes some way to reproducing the effects of natural environments.

Furthermore, considering natural environments for corrosion on metallic materials, neutral or acidified salt solution spray, humid, and dry conditions are also important factors as a cyclic corrosion test. Each condition is repeated after intervals of other conditions in different combinations to achieve corrosion on metallic materials and to get acceleration of corrosion.

The tests described in this document are accelerated compared with most expected conditions of use. As a result, it may be difficult to establish an overall acceleration factor for all kinds of test specimens. This also means that it is often not possible to use results gained from these tests as a comparative guide to the long-term behaviour of different coating systems since the corrosion stress during these tests differs significantly from the corrosion stresses encountered during use. Nevertheless, the method described gives a means of checking that the comparative quality of a metallic material is maintained.

This document may involve hazardous materials, operations and equipment. This document does not purport to address all of the safety concerns, if any, associated with its use. It is the responsibility of the user of this document to establish appropriate safety and health practices and determine the applicability of regulatory limitations prior to use.

ENVIRONMENTAL TESTING –

Part 2-52: Tests – Test Kb: Salt mist, cyclic (sodium chloride solution)

1 Scope

This part of IEC 60068-2 specifies the application of the cyclic salt mist test to components or equipment designed to withstand a salt-laden atmosphere as salt can degrade the performance of parts manufactured using metallic and/or non-metallic materials.

2 Normative references

The following documents are referred to in the text in such a way that some or all of their content constitutes requirements of this document. For dated references, only the edition cited applies. For undated references, the latest edition of the referenced document (including any amendments) applies.

IEC 60068-1, *Environmental testing – Part 1: General and guidance*

IEC 60068-2-78, *Environmental testing – Part 2-78: Tests – Test Cab: Damp heat, steady state*

ISO 9227, *Corrosion tests in artificial atmospheres – Salt spray tests*

3 Terms and definitions

No terms and definitions are listed in this document.

ISO and IEC maintain terminological databases for use in standardization at the following addresses:

- IEC Electropedia: available at <http://www.electropedia.org/>
- ISO Online browsing platform: available at <http://www.iso.org/obp>

4 General description of the test

4.1 Description of each test condition

4.1.1 General

This document consists of the cyclic test conditions of salt mist, dry condition, humid condition and standard atmosphere. The effect of each test condition is as follows.

NOTE Salt mist is also called salt spray.

The test specimen(s) is typically not energized during the test.

4.1.2 Salt mist

The test specimen is corroded by an electrochemical or complex chemical reaction with neutral or acidified salt solution. Salt solution forms a thin electrolytic film on the test specimen surface. This can initiate corrosion and can allow it to proceed.

4.1.3 Dry condition

Heated air in the chamber may cause evaporation of water from the test specimen surface from decreasing relative humidity and increased specimen temperature. This causes the concentration of the solution to increase and speeds up chemical reactions, accelerating the corrosion process. Salt precipitates out of the solution onto the test specimen surface during this condition. Evaporation and heating rates may vary based on the test chamber and test specimen.

4.1.4 Humid condition

4.1.4.1 Dry condition to humid condition

As the relative humidity increases, precipitated salt crystals on the specimen surface absorb water vapour until a liquid electrolytic solution forms, reinitializing the corrosion process.

4.1.4.2 Salt mist to humid condition

The humid condition maintains the existing wetness on the test specimen surface at the end of the salt mist period, without excessive dilution of the solution that may result from condensing humidity.

4.1.5 Standard atmosphere

The test specimen is allowed to equilibrate with standard laboratory conditions, which results in gradual drying and relaxation from most corrosion reactions. The period of dry atmosphere may occur, in practice, during breaks of operation, for example during the weekend. The inclusion of such a dry period may lead to corrosion mechanisms which can be quite different from those under constant wet conditions. The test schedule shall be chosen in order to respect the timelines given in 9.4. Additional dry periods (e.g. during a weekend) shall be avoided.

5 Test apparatus

5.1 General

Each test method includes two or more environmental conditions, which may be achieved by the use of multiple chambers or a single chamber that automatically transitions from one condition to the next. In either case, transitions are not assumed to be instantaneous. Care shall be taken to minimize any adverse effects associated with handling of specimens during transfer between chambers.

5.2 Salt mist chamber

The chamber shall conform to the requirements of ISO 9227. It shall maintain a temperature of $35\text{ °C} \pm 2\text{ K}$.

NOTE A schematic diagram of one possible design of spray cabinet is shown in Annex A.

5.3 Humidity chamber

The chamber shall conform to the requirements of IEC 60068-2-78. It shall maintain a relative humidity of $93\% \pm 3\%$ at a temperature of $40\text{ °C} \pm 2\text{ K}$ or a relative humidity of over 95% at a temperature of $50\text{ °C} \pm 2\text{ K}$.

5.4 Standard atmosphere chamber

The chamber shall conform to the requirements of IEC 60068-1. It shall maintain a relative humidity of 50 % \pm 5 % at a temperature of 23 °C \pm 2 K.

5.5 Dry chamber

The chamber shall maintain a relative humidity of less than 30 % at a temperature of 60 °C \pm 2 K.

6 Salt solution

6.1 Preparation of the sodium chloride solution

The solution shall conform to the requirements of ISO 9227.

NOTE The sodium chloride concentration of the sprayed solution collected is 50 g/l \pm 5 g/l.

6.2 pH adjustment

6.2.1 Neutral salt solution

The pH adjustment shall conform to the requirements of ISO 9227 for the neutral salt solution test.

6.2.2 Acidified salt solution

Add the following reagents to 10 litres of the prepared neutral 5 % sodium chloride solution as follows: 12 ml of nitric acid (HNO_3 , $\rho = 1,42$ g/ml), 17,3 ml of sulfuric acid (H_2SO_4 , $\rho = 1,84$ g/ml) and sufficient quantity of 10 % mass fraction of sodium hydroxide (NaOH) solution to adjust the pH of the solution to $3,5 \pm 0,1$ (about 300 ml will be required). The pH of the sprayed solution collected within the chamber is 3,4 to 3,6 at 25 °C \pm 2 K.

6.3 Filtration

If necessary, filter the solution before placing it in the reservoir of the apparatus to remove any solid matter which might block the apertures of the spraying device.

7 Initial measurements

The test specimen(s) shall be visually inspected and, if necessary, electrically and mechanically checked as required by the relevant specification.

8 Preconditioning

The relevant specification shall specify the cleaning procedure to be applied immediately before the test; it shall also state whether temporary protective coatings shall be removed.

The cleaning method used should not interfere with the effect of the salt mist on the test specimen(s), nor introduce any secondary corrosion. Touching of the test surfaces by hand should be avoided as far as possible before the test.

9 Testing

9.1 Test chamber

For test methods 1 and 2, a salt mist chamber and humidity chamber are used.

For test methods 3 to 6, a salt mist chamber, humidity chamber and standard atmosphere chamber are used.

For test methods 7 and 8, a salt mist chamber, dry chamber and humidity chamber are used.

All test methods may be performed in a single chamber provided it is capable of maintaining the required conditions. If not, care should be taken to avoid loss of salt solution deposits on the test specimen(s) and to avoid any damage to the test specimen(s) due to manual handling. For test methods 7 and 8, each condition should be carried out in the same chamber due to the difficulty in achieving the rapid drying and re-wetting intended if specimens are manually moved from one chamber to another.

It is recommended to use a specific chamber for testing test method 8 exclusively. Cross effects of remaining acidified salt solution when consequently using test method 1 to 7 cannot be ignored.

9.2 Arrangement of the test specimen(s)

The arrangement shall conform to the requirements of ISO 9227.

9.3 Conditions during salt mist

The test conditions shall conform to the requirements of ISO 9227.

9.4 Test methods

9.4.1 General

The relevant specification shall indicate which of the eight following test methods shall be used. A description of each test method is given in Annex B. When not specified, the test method shall be agreed by the interested parties.

The user should be aware of mass loss for each test condition.

9.4.2 Test method 1

One cycle is seven days. One cycle shall consist of spraying the specimen with a salt solution at $35\text{ °C} \pm 2\text{ K}$ for 2 h, followed by the humid condition at $40\text{ °C} \pm 2\text{ K}$, $93\% \pm 3\% \text{ RH}$ for six days and 22 h. The required number of cycles is four (28 days).

In the case of manual handling, the transition time (maximum 2 h) should be included in the humid condition period of six days and 22 h.

9.4.3 Test method 2

One cycle is one day. One cycle shall consist of spraying the specimen with a salt solution at $35\text{ °C} \pm 2\text{ K}$ for 2 h, followed by the humid condition at $40\text{ °C} \pm 2\text{ K}$, $93\% \pm 3\% \text{ RH}$ for 22 h. The required number of cycles is three (three days).

In the case of manual handling, the transition time (maximum 2 h) should be included in the humid condition period of 22 h.

9.4.4 Test method 3

One cycle is seven days. One cycle shall consist of spraying the specimen with a salt solution at $35\text{ °C} \pm 2\text{ K}$ for 2 h, followed by the humid condition at $40\text{ °C} \pm 2\text{ K}$, $93\% \pm 3\% \text{ RH}$ for 22 h. This shall be repeated four times. The test specimens shall then be stored under standard atmosphere at $23\text{ °C} \pm 2\text{ K}$ and $50\% \pm 5\% \text{ RH}$ for three days. The required number of cycle is one (seven days).

In the case of manual handling, the transition time (maximum 2 h) should be included in the humid condition period of 22 h and standard atmosphere period of three days.

9.4.5 Test method 4

The required number of cycles as specified in test method 3 shall be two (14 days).

9.4.6 Test method 5

The required number of cycles as specified in test method 3 shall be four (28 days).

9.4.7 Test method 6

The required number of cycles as specified in test method 3 shall be eight (56 days).

9.4.8 Test method 7

One cycle is 8 h. One cycle shall consist of spraying the specimen with a salt solution at $35\text{ }^{\circ}\text{C} \pm 2\text{ K}$ for 2 h, followed by the dry condition at $60\text{ }^{\circ}\text{C} \pm 2\text{ K}$, under 30 % RH for 4 h and then the humid condition at $50\text{ }^{\circ}\text{C} \pm 2\text{ K}$, over 95 % RH for 2 h.

The transition times (time allowed to reach the temperature and relative humidity specified for a condition after changing to that condition) for temperature and humidity shall be specified between the following choices and reported:

- salt mist to dry condition: within 30 min or between 30 min and 60 min;
- dry condition to humid condition: within 15 min or between 15 min and 30 min;
- humid condition to salt mist: within 30 min.

Those transition times shall be included in the next condition period of the pair, for example the salt mist to dry condition transition time is included in the period of the dry condition. Spraying the specimen with a salt solution begins instantaneously once the salt mist is started.

The recommended number of cycles are 3 (1 day), 6 (2 days), 12 (4 days), 30 (10 days), 45 (15 days), 60 (20 days), 90 (30 days), 150 (50 days) and 180 (60 days).

9.4.9 Test method 8

One cycle is 8 h, as specified in test method 7 using acidified salt solution instead of neutral salt solution.

The recommended number of cycles is the same as in test method 7.

9.5 Test cycles for test methods 1 to 8

The test cycles for test methods 1 to 8 shall be in accordance with Table 1.

Table 1 – Test cycles for test methods 1 to 8

Test methods	Details of the cycle	Recommended number of cycles
Test method 1	<p>One cycle = 7 days</p> <p>In the case of manual handling, the transition time (max. 2 h) should be included in the humid condition period of 6 days and 22 h.</p>	4 cycles (28 days)
Test method 2	<p>One cycle = 1 day</p> <p>In the case of manual handling, the transition time (max. 2 h) should be included in the humid condition period of 22 h.</p>	3 cycles (3 days)
Test method 3	<p>Repeat 4 times</p> <p>One cycle = 7 days</p> <p>In the case of manual handling, the transition time (max. 2 h) should be included in the humid condition period of 22 h and standard atmosphere period of 3 days.</p>	1 cycle (7 days)
Test method 4		2 cycles (14 days)
Test method 5		4 cycles (28 days)
Test method 6		8 cycles (56 days)
Test method 7	<p>One cycle = 8 h</p>	3, 6, 12, 30, 45, 60, 90, 150, 180 cycles
Test method 8	<p>The transition times (time allowed to reach the temperature and relative humidity specified for a condition after changing to that condition) are within 30 min or between 30 min and 60 min from salt mist to dry condition, within 15 min or between 15 min and 30 min from dry condition to humid condition and within 30 min from humid condition to salt mist. Those transition times shall be included in next condition period.</p>	(1, 2, 4, 10, 15, 20, 30, 50, 60 days)
<p>NOTE The ± tolerances given for temperature and relative humidity are the allowable fluctuations which are defined as the positive and negative deviations from the setting of the sensor at the operational control set point during equilibrium conditions. This does not mean that the set value can vary by plus/minus the amount indicated from the given value.</p>		

9.6 Removal of the test specimen(s)

The test is recommended to be carried out in the same chamber (see Figure A.1). If not, care should be taken to avoid loss of salt solution deposits on the test specimen(s) and to avoid any damage to the test specimen(s) due to handling.

10 Recovery (at the end of testing)

The relevant specification shall state whether or not the test specimen(s) shall be washed. If the test specimen(s) is to be washed, it shall be washed using running tap water for 5 min,

rinsed in distilled or deionized water, shaken by hand or subjected to air blast to remove droplets of water, then dried for 1 h at $55\text{ °C} \pm 2\text{ K}$ and allowed to cool under controlled recovery conditions (IEC 60068-1) for not less than 1 h and not more than 2 h.

The relevant specification shall provide, if needed, other methods for washing and drying the test specimen(s). The specimen shall be stored under controlled recovery conditions (IEC 60068-1) for not less than 1 h and not more than 2 h. The temperature of the water used for washing shall not exceed 35 °C .

11 Final measurements

The test specimen(s) shall be subjected to visual, dimensional and functional checks specified by the relevant specification.

The relevant specification shall provide the criteria upon which the acceptance or rejection of the test specimen(s) is to be based.

12 Information to be given in the relevant specification

The following details shall be given, in so far as they are applicable in the relevant specification, paying particular attention to the items marked with an asterisk (*), as this information is always required.

- a) salt solution, if different from that specified in 6.1 (see Clause 6);
- b) initial measurements* (see Clause 7);
- c) preconditioning (see Clause 8);
- d) appropriate test method* (see Clause 9);
- e) recovery conditions (see Clause 10);
- f) final measurements* (see Clause 11).

13 Information to be given in the test report

The following details shall be given in the test report, where applicable:

- a) test standard (IEC 60068-2-52:2017);
- b) test dates (dates when test was run);
- c) testing test method, one of 1 to 8;
- d) preconditioning;
- e) method and results of initial measurement;
- f) conditions and duration of test;
- g) operation and loading during test;
- h) recovery conditions and duration;
- i) method and results of final measurement (see Clause 11);
- j) any deviation from this document;
- k) any unusual features observed.

Annex A
(informative)

Typical apparatus for cyclic salt mist, humid condition, dry condition and standard atmosphere corrosion tests

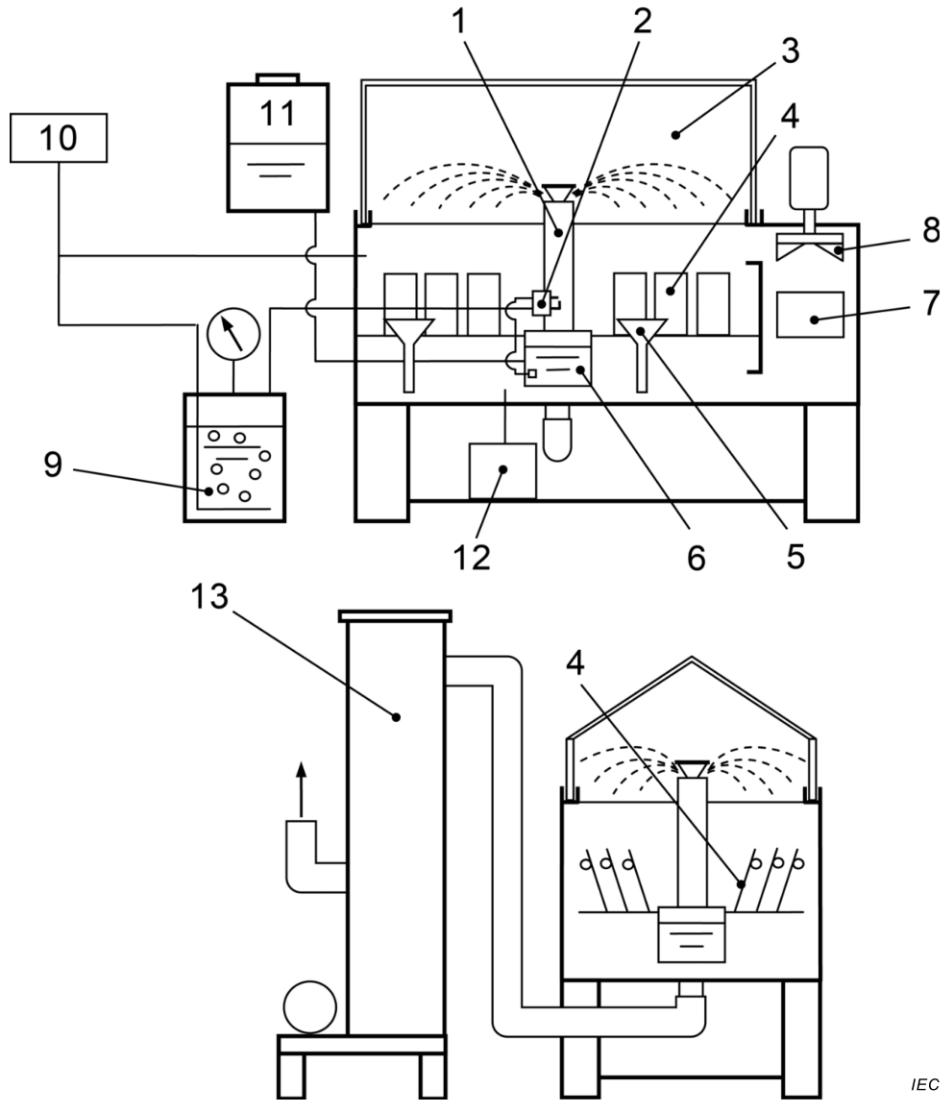

IEC

Key

- | | | |
|-------------------------|----------------------|-------------------------------|
| 1 Mist dispersion tower | 6 Solution reservoir | 11 Solution tank |
| 2 Atomizer | 7 Heater | 12 Humidifier |
| 3 Test chamber | 8 Agitating fan | 13 Exhaust air treatment unit |
| 4 Test specimen | 9 Saturation tower | |
| 5 Collecting device | 10 Compressed air | |

Figure A.1 – Example of test apparatus

Annex B (informative)

Description of each test method

B.1 Test methods 1 and 2

Test methods 1 and 2 are commonly used as a general corrosion test in component quality assurance procedures.

Test methods 1 and 2 can be used for testing products which are used in a marine environment, or in close proximity to the sea. Test method 1 should be used to test products which are exposed to the environment for much of their operational life (e.g. ship radar, deck equipment). Test method 2 should be used to test products which may be exposed to the marine environment from time to time but will normally be protected by an enclosure (e.g. navigational equipment which will normally be used on the bridge or in a control room).

For test methods 1 and 2, the test procedure is separated into a specified number of periods of spraying with a salt solution each followed by a storage period under humid conditions.

B.2 Test methods 3 to 6

Test methods 3 to 6 can be used for products where, under normal use, there is a frequent change between salt-laden and dry atmosphere, for example automobiles and their parts.

Test methods 3 to 6, compared to test methods 1 and 2, include an additional storage exposure under a standard atmosphere.

For test methods 3 to 6, the test procedure is separated into a specified number of test cycles. Each test cycle consists of four periods of spraying with a salt solution each followed by a storage period under humid conditions, and of one storage period under standard atmosphere after these four periods of spraying and storage under humid conditions.

B.3 Test methods 7 and 8

Test method 7 defines a specific number of test cycles that include spraying salt mist, followed by dry conditions and humid conditions. The process can be used as a general corrosion test for many materials including automobiles and their parts.

Test method 8 contains the same cyclic exposure as test method 7, but utilizes an acidified salt solution instead of a neutral salt solution to induce a corrosion that occurs in acidified salt environment.

Test methods 7 and 8, dry conditions provide a correlation with real-world corrosion for metals and their alloys, as well as plating and coatings. It can be used as a quality control test or for material qualification, where test repeatability is very important.

Bibliography

- [1] JASO M 609-91, *Corrosion test method for automotive materials*, Published by the Society of Automotive Engineering in Japan
 - [2] JASO M 610-92, *Cosmetic corrosion test method for automotive parts*, Published by the Society of Automotive Engineering in Japan
 - [3] Townsend H. E., Davidson D. D. and Ostermiller M. R., *Development of laboratory corrosion tests by the automotive and steel industries of north america*, The 4th International Conference on Zinc and Zinc Alloy Coated Steel Sheet (GALVATECH'98), Chiba, Japan, 1998, pp. 659-666
 - [4] Shigeru Suga and Shigeo Suga, *Report on the results from the ISO/TC 156/WG 7 International Round Robin Test Programme on ISO 9227 Salt spray tests*; J. Surface Finish. Soc. Japan; Vol. 56, p. 28 (2005)
 - [5] Shigeru Suga and Shigeo Suga, *Development of Simulated Acid Rain Test Using CCT Method; Accelerated and Outdoor Durability Testing of Organic Materials*; ASTM STP 1202, (1994)
-

INTERNATIONAL
ELECTROTECHNICAL
COMMISSION

3, rue de Varembé
PO Box 131
CH-1211 Geneva 20
Switzerland

Tel: + 41 22 919 02 11
Fax: + 41 22 919 03 00
info@iec.ch
www.iec.ch